

FlexRmTM
BY FROMM



FROMM | WRAPPING SOLUTIONS

FS380 FlexRm

Stretch Wrapping Machine
with Articulated Arm

www.fromm-pack.com

FS380 FlexRm™

75
YEARS
1947 – 2022

Based on FS380 technology, the FlexRm™ is not only recognised for its low build of 1.480 mm (58") in zero position but, also by its attractive purchase price and expansion options. In addition, the conveniently positioned Lexan control panel, offers a wide range of operating options, accessible to everyone. The use of widely available branded parts, including electronics and motors, optimizes operational reliability and reduces maintenance requirements to a minimum. The highest possible personal safety and ease of use are inherent in its design.

With a standard weight of 400 Kg. (881 lbs) and the arm in the 0 position, the FlexRm™ can easily be moved to alternative wrapping locations within your company, using a forklift truck.

Fitted as standard with a film carriage with mechanical brake, the FlexRm™ can also be easily upgraded to a higher level at a later date. A total of 4 types of film carriages are available for this machine.

The FlexRm™ also allows a wide variety of turntables for your every need. Here you can choose from 6 different sizes and models.

These are just a few examples from the extensive range of options for the FlexRm™. Below we give you an overview of the most commonly used.

Some technical details of the FlexRm™:

- Power: 230V-50/60Hz - 1ph - 1,0 Kw. - 6.0A
- Programs— PLC up to 99 free programmable
- Max. capacity* <25 pallets / hr. *) depending on pallet dimensions, configuration,
- Film quality & environment
- Processes pre-stretched or standard stretch films from 8 – 30 micron
- Wrapping height, max. 2.400 mm (7.9 ft)- pallet included
- Photosensors for load detection
- Rotation speed, adjustable between 5 - 12 rpm.
- Soft start & stop are standard
- Vertical—up & down—carriage speed, independently adjustable between 1,3 and 5,4 m/min.
- Machine dimensions : Height: min. 1.480 - (4.9 ft) max. 2.700 mm (8.9 ft) / width and length depending on the selected turntable type and diameter.

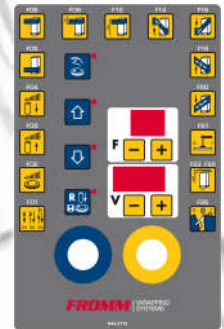

Wide selection of machine options

- Film carriages, choice of 4 types; CA2 mechanical brake, CA4 magnetic brake, CA6 One-motor Pre-stretch (with gears for 150, 200 and 250%) and the CA7 Two-motors powered Pre-stretch
- Film roping, multiple film strip cutting and film end cutting
- Turntable sizes available - 1.500 (std) , 1.650, 1.800, 2.200, 2.400 and 2.600 mm (4.9, 5.4, 5.9, 7.2, 7.8 and 8.5 ft)
- Standard turntable, max load 2.000Kgs. (4,409 lbs) Optional increased weight load up to 3.000kg (6,613 lbs)
- Ultra-Low 25 mm (1") turntable of 1.650 mm (5.4 ft), max. load capacity 1.200 Kg. (2,645 lbs)
- "Horse-shoe" turn table, dimensions 1.650 (5.4 ft) or 1.800 mm (5.9 ft). Max. load capacity 1.200 Kg. (2,645 lbs)
- Loading ramps available for standard and heavy loads
- Load weighing systems
- Floor mounting frame, recessed into the floor

What is in it for you as the owner of a FlexRm™?

- Economic all-rounder for fast and energy efficient working
- Compact - low freight costs and easy to move.
- Easy installation - plug and play - no special installation required
- Requires virtually no maintenance
- The FlexRM is suitable for low ceiling environments
- Excellent human interface and easy to operate for multiple operators
- Extensive choice of options and modular design makes this machine easily adaptable

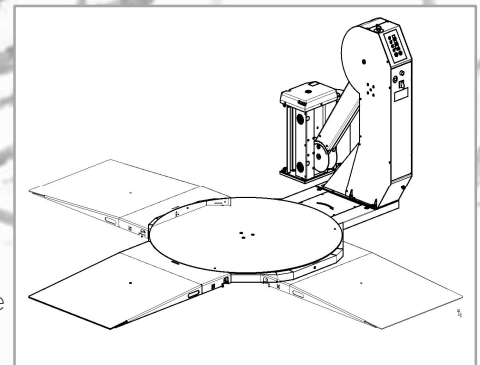

FROMM | WRAPPING SOLUTIONS

www.fromm-pack.com

Your FROMM distributor